

**British Polythene Limited**  
**t/a Visqueen Building Products**

Heanor Gate  
Heanor  
Derbyshire DE75 7RG

Tel: 0845 302 4758 Fax: 0845 017 8663  
e-mail: [enquiries@visqueenbuilding.co.uk](mailto:enquiries@visqueenbuilding.co.uk)  
website: [www.visqueen.com](http://www.visqueen.com)



**Agrément Certificate**  
**94/3009**  
Product Sheet 2

**VISQUEEN DAMP-PROOF MEMBRANES**

**VISQUEEN HIGH PERFORMANCE DPM**

This Agrément Certificate Product Sheet<sup>(1)</sup> relates to Visqueen High Performance DPM, a 0.5 mm thick co-polymer thermoplastic damp-proof membrane (dpm) for use in solid concrete ground floors not subject to hydrostatic pressure, to protect buildings against moisture from the ground.

(1) Hereinafter referred to as 'Certificate'.

**CERTIFICATION INCLUDES:**

- factors relating to compliance with Building Regulations where applicable
- factors relating to additional non-regulatory information where applicable
- independently verified technical specification
- assessment criteria and technical investigations
- design considerations
- installation guidance
- regular surveillance of production
- formal three-yearly review.

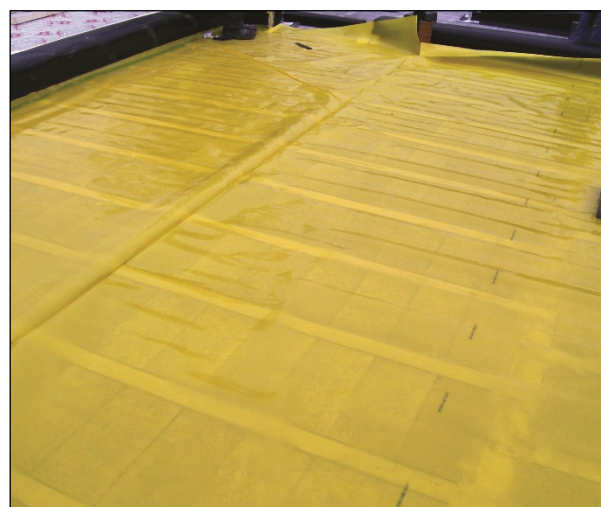

**KEY FACTORS ASSESSED**

**Resistance to water and water vapour** — the product, including joints, will resist the passage of moisture into the structure (see section 6).

**Resistance to puncture** — the product, installed on a smooth or blinded surface, will not be damaged by foot or site traffic (see section 7).

**Durability** — under normal service conditions, the product will provide an effective barrier to the transmission of moisture for the life of the structure in which it is incorporated (see section 10).

The BBA has awarded this Certificate to the company named above for the product described herein. This product has been assessed by the BBA as being fit for its intended use provided it is installed, used and maintained as set out in this Certificate.

On behalf of the British Board of Agrément

Date of Third issue: 6 December 2021

Originally certificated on 10 December 2013

Hardy Giesler  
Chief Executive Officer

*The BBA is a UKAS accredited certification body – Number 113.*

*The schedule of the current scope of accreditation for product certification is available in pdf format via the UKAS link on the BBA website at [www.bbacerts.co.uk](http://www.bbacerts.co.uk)  
Readers MUST check the validity and latest issue number of this Agrément Certificate by either referring to the BBA website or contacting the BBA directly.*

*Any photographs are for illustrative purposes only, do not constitute advice and should not be relied upon.*

**British Board of Agrément**

Bucknalls Lane  
Watford  
Herts WD25 9BA

©2021

tel: 01923 665300  
[clientservices@bbacerts.co.uk](mailto:clientservices@bbacerts.co.uk)  
[www.bbacerts.co.uk](http://www.bbacerts.co.uk)

## Regulations

In the opinion of the BBA, Visqueen High Performance DPM, if installed, used and maintained in accordance with this Certificate, can satisfy or contribute to satisfying the relevant requirements of the following Building Regulations (the presence of a UK map indicates that the subject is related to the Building Regulations in the region or regions of the UK depicted):



### The Building Regulations 2010 (England and Wales) (as amended)

|                     |              |  |
|---------------------|--------------|--|
| <b>Requirement:</b> | <b>C2(a)</b> | <b>Resistance to moisture</b>  |
| Comment:            |              | The product, including joints, will enable a floor to satisfy this Requirement. See section 6 of this Certificate. |
| <b>Regulation:</b>  | <b>7(1)</b>  | <b>Materials and workmanship</b>   |
| Comment:            |              | The product is acceptable. See section 10.1 and the <i>Installation</i> part of this Certificate.                  |



### The Building (Scotland) Regulations 2004 (as amended)

|                    |               |  |
|--------------------|---------------|--|
| <b>Regulation:</b> | <b>8(1)</b>   | <b>Durability, workmanship and fitness of materials</b>  |
| Comment:           |               | The use of the product satisfies the requirements of this Regulation. See section 10.1 and the <i>Installation</i> part of this Certificate.   |
| <b>Regulation:</b> | <b>9</b>      | <b>Building standards applicable to construction</b>   |
| Standard:          | <b>3.4</b>    | Moisture from the ground   |
| Comment:           |               | The product, including joints, will enable a floor to satisfy the requirements of this Standard, with reference to clauses 3.4.1 <sup>(1)(2)</sup> , 3.4.2 <sup>(1)(2)</sup> and 3.4.4 <sup>(1)(2)</sup> to 3.4.6 <sup>(1)(2)</sup> . See section 6 of this Certificate. |
| <b>Standard:</b>   | <b>7.1(a)</b> | <b>Statement of sustainability</b>   |
| Comment:           |               | The product can contribute to satisfying the relevant requirements of Regulation 9, Standards 1 to 6, and therefore will contribute to a construction meeting a bronze level of sustainability as defined in this Standard.  |
| <b>Regulation:</b> | <b>12</b>     | <b>Building standards applicable to conversions</b>  |
| Comment:           |               | All comments given for the product under Regulation 9, Standards 1 to 6, also apply to this Regulation, with reference to clause 0.12.1 <sup>(1)(2)</sup> and Schedule 6 <sup>(1)(2)</sup> .   |

(1) Technical Handbook (Domestic).  
(2) Technical Handbook (Non-Domestic).



### The Building Regulations (Northern Ireland) 2012 (as amended)

|                    |                    |   |
|--------------------|--------------------|---|
| <b>Regulation:</b> | <b>23(a)(i)</b>    | <b>Fitness of materials and workmanship</b>   |
| Comment:           | <b>(iii)(b)(i)</b> | The product is acceptable. See section 10.1 and the <i>Installation</i> part of this Certificate.                                     |
| <b>Regulation:</b> | <b>28(a)</b>       | <b>Resistance to moisture and weather</b>   |
| Comment:           |                    | The product, including joints, will enable a floor to satisfy the requirements of this Regulation. See section 6 of this Certificate. |

## Construction (Design and Management) Regulations 2015

## Construction (Design and Management) Regulations (Northern Ireland) 2016

Information in this Certificate may assist the client, designer (including Principal Designer) and contractor (including Principal Contractor) to address their obligations under these Regulations.

See section: 1 *Description* (1.2) of this Certificate.

## Additional Information

### NHBC Standards 2021

In the opinion of the BBA, Visqueen High Performance DPM, if installed, used and maintained in accordance with this Certificate, can satisfy or contribute to satisfying the relevant requirements in relation to *NHBC Standards*, Chapter 5.1 *Substructure and ground bearing floors*, clause 5.1.20 *Damp-proofing concrete floors*.

### CE marking

The Certificate holder has taken the responsibility of CE marking the product, in accordance with harmonised European Standard BS EN 13967 : 2012.

## Technical Specification

### 1 Description

1.1 Visqueen High Performance DPM is a 0.5 mm thick, co-polymer thermoplastic membrane containing low-density polyethylene, coloured yellow.

1.2 The membrane has the nominal characteristics given in Table 1.

| Characteristic (unit)  | Visqueen High Performance DPM |
|--|-------------------------------|
| Thickness (mm)   | 0.5                           |
| Roll length (m)  | 12.5                          |
| Roll width (m)   | 4                             |
| Mass per unit area ( $\text{g}\cdot\text{m}^{-2}$ )                      | 460                           |
| Tensile strength ( $\text{N}\cdot\text{mm}^{-2}$ )                       | 20                            |
| MD   | 20                            |
| CD   |                               |
| Elongation (%)   |                               |
| MD   | 675                           |
| CD   | 665                           |
| Nail-tear resistance (N)   |                               |
| MD   | 333                           |
| CD   | 335                           |
| Watertightness (2 kPa)   | Pass                          |
| Water vapour transmission ( $\text{MN}\cdot\text{s}\cdot\text{g}^{-1}$ ) | 2100                          |

1.3 Standard rolls are centre-folded along their length. Multi-folded format for an easier handling option is also available.

1.4 Ancillary products used with the membrane are:

- VisqueenPro double sided tape - tape used to bond adjacent sheets of the product and for bonding the product to a damp-proof course (DPC)
- VisqueenPro single sided tape - tape used to seal laps of the product and for sealing laps of the product to a damp-proof course (DPC)
- VisqueenPro Detailing Strip - for the effective sealing of complex junctions and stanchions. Can also be used for repairing areas of minor damage to the membrane
- TreadGUARD 1500 — a heavy-duty protection layer
- TreadGUARD 300 — a medium-duty protection blanket.

### 2 Manufacture

2.1 The product is manufactured from recycled polyethylene by an extrusion process.

2.2 As part of the assessment and ongoing surveillance of product quality, the BBA has:

- agreed with the manufacturer the quality control procedures and product testing to be undertaken
- assessed and agreed the quality control operated over batches of incoming materials
- monitored the production process and verified that it is in accordance with the documented process
- evaluated the process for management of nonconformities
- checked that equipment has been properly tested and calibrated
- undertaken to carry out the above measures on a regular basis through a surveillance process, to verify that the specifications and quality control operated by the manufacturer are being maintained.

2.3 The management system of Visqueen Building Products has been assessed and registered as meeting the requirements of BS EN ISO 9001 : 2015 by SGS Ltd (Certificate GB17/873194).

### 3 Delivery and site handling

3.1 Rolls are supplied on pallets, in wrappers bearing the Certificate holder's and product names, and the BBA logo incorporating the number of this Certificate.

3.2 Rolls should be stored under cover and protected from sunlight.

## Assessment and Technical Investigations

The following is a summary of the assessment and technical investigations carried out on Visqueen High Performance DPM.

### Design Considerations

## 4 Use

4.1 Visqueen High Performance DPM is satisfactory for use as a dpm in concrete floors not subject to hydrostatic pressure, in accordance with the relevant clauses of CP 102 : 1973, section 3.

4.2 The product can be installed as an oversite membrane, between a blinded hardcore bed and the base concrete slab, as a sandwich membrane in a base concrete slab, or between the base concrete slab and the screed.

4.3 The product will remain flexible at temperatures likely to occur in practice.

## 5 Practicability of installation

Installation is designed to be carried out by a competent general builder, or a contractor, experienced with this type of product.

## 6 Resistance to water and water vapour



6.1 The membrane and the methods of jointing provide an effective barrier to the passage of moisture from the ground

6.2 The membrane complies with the minimum sheet thickness detailed in the documents supporting the national Building Regulations.

## 7 Resistance to puncture

7.1 On smooth or blinded surfaces the product will accept, without damage, the limited foot traffic and loads associated with installation (see section 13.5).

7.2 The membrane can be punctured by sharp objects and care should be taken to avoid damage during installation, particularly when handling building materials and equipment over the surface and when placing concrete or screeds.

## 8 Underfloor heating

When used in accordance with this Certificate, there will be no adverse effect on the product from underfloor heating under normal operating conditions. However, the Certificate holder's advice should be sought for specific applications.

## 9 Maintenance

As the product is confined and has suitable durability (see section 10), maintenance is not required. Any damage occurring during installation must be repaired prior to overlaying with concrete (see section 14).

## 10 Durability



10.1 When subject to normal conditions of use, the product will provide an effective barrier to the transmission of moisture for the life of the floor in which it is installed.

10.2 Long periods of exposure to ultraviolet light will reduce the effectiveness of the product and it should be protected from such exposure during storage and installation.

## 11 Reuse and recyclability

The product contains polyethylene, which can be recycled.

## Installation

### 12 General

12.1 Installation of Visqueen High Performance DPM must be in accordance with the Certificate holder's instructions, CP 102 : 1973, clause 11, the relevant clauses of BS 8000-0 : 2014 and BS 8000-4 : 1989, and section 13 of this Certificate.

12.2 The product should be kept clean and free from dirt and grease.

12.3 Unless the base is smooth, a surface blinding of soft sand (or similar material) must be used to prevent puncturing during installation or when the concrete or screed is being placed.

12.4 The product can be installed in all conditions normal to ground floor slab construction. Where there is a risk of ground becoming waterlogged, sub-soil drainage must be provided in accordance with CP 102 : 1973.

12.5 The type of floor finish to be used may limit the suitability of polyethylene dpms; the guidance given in CP 102 : 1973 should be followed.

### 13 Procedure

13.1 Adjacent sheets are overlapped by at least 150 mm, bonded with VisqueenPro double-sided tape and sealed using VisqueenPro single-sided tape (see Figure 1).

**Figure 1 Typical tape joint**

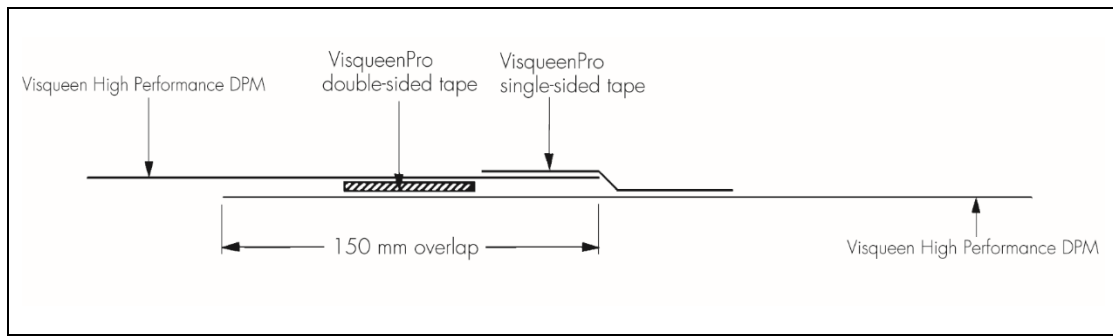

13.2 Alternatively, when it is not possible to keep a sheet dry, a double-welted fold can be formed using at least 300 mm of the membrane. It is essential that weights, eg bricks, are used to maintain the fold in position prior to placing the concrete (see Figure 2).

**Figure 2 Double-welted fold joint**

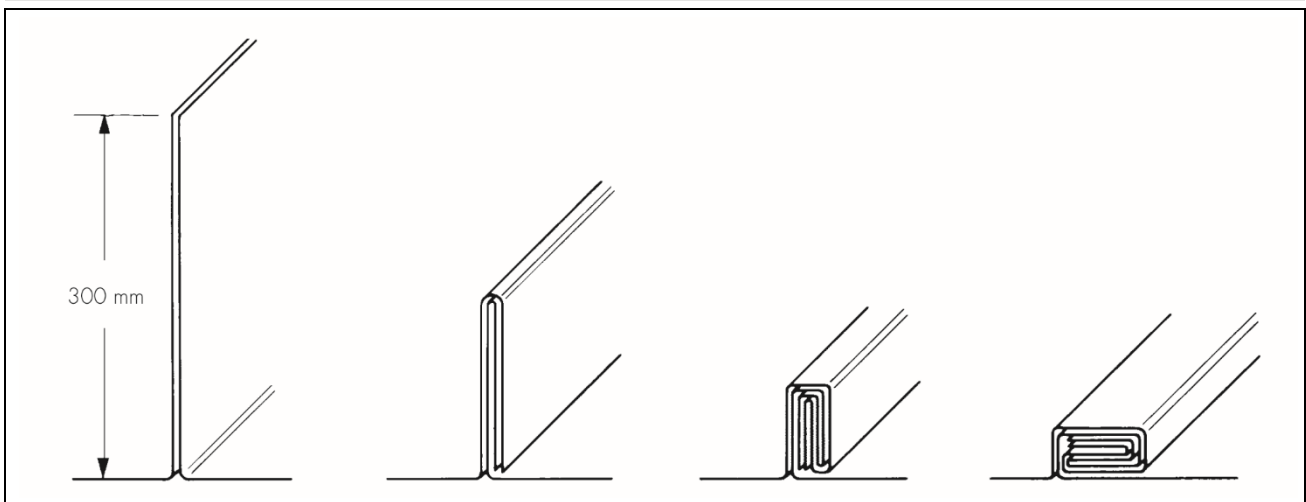

13.3 Perforations or punctures in the sheets must be patched with sheets of identical thickness, lapped at least 150 mm beyond the limits of the puncture and the laps bonded with VisqueenPro double sided tape and sealed with VisqueenPro single sided tape.

13.4 The dpm must be continuous with the dpc in the surrounding walls. Where necessary, the product is used as a vertical dpc to link the two. The dpm and the dpc joint must be overlapped by a minimum of 100 mm and the laps bonded with VisqueenPro double sided tape and sealed with VisqueenPro single sided tape. Where there is doubt about the compatibility of materials, the advice of the Certificate holder should be sought.

13.5 The membrane must be covered with Visqueen TreadGUARD 1500, Visqueen TreadGUARD 300, a screed or other protective layer as soon as possible after installation. Care must be taken to ensure that the membrane is not stretched or displaced and to avoid the creation of areas of unsupported membrane when placing the concrete or screed, for example at internal angles.

## 14 Repair

Before permanent protection is placed, the membrane area must be inspected for defects. Damage to the product must be repaired using VisqueenPro Detailing Strip, or, if a larger repair is required, by using a patch of the membrane and bonding the laps with VisqueenPro double-sided tape and sealing the laps with VisqueenPro single-sided tape. All patches must extend a minimum of 150 mm from the damaged area.

### 15 Tests

15.1 An assessment was made of data in relation to:

- mass per unit area
- density
- water vapour permeability
- water vapour resistance
- static indentation
- low temperature flexibility
- dimensional stability
- watertightness
- heat ageing 70° for 84 days followed by tensile strength and elongation, nail tear resistance and watertightness
- short-term UV ageing, followed by tensile strengths and elongation.

15.2 Test on joints were carried out to determine:

- tensile strength of joints
- heat aged 70° for 84 days followed by tensile strength and elongation.

### 16 Investigations

The manufacturing process was evaluated, including the methods adopted for quality control, and details were obtained of the quality and composition of the materials used.

## Bibliography

BS 8000-0 : 2014 *Workmanship on construction sites — Introduction and general principles*

BS 8000-4 : 1989 *Workmanship on building sites — Code of practice for waterproofing*

BS EN 13967 : 2012 +A1 : 2017 *Flexible sheets for waterproofing — Plastic and rubber damp proof sheets including plastic and rubber basement tanking sheet — Definitions and characteristics*

BS EN ISO 9001 : 2015 *Quality Management Systems — Requirements*

CP 102 : 1973 *Code of practice for protection of buildings against water from the ground*

### 17 Conditions

17.1 This Certificate:

- relates only to the product/system that is named and described on the front page
- is issued only to the company, firm, organisation or person named on the front page – no other company, firm, organisation or person may hold or claim that this Certificate has been issued to them
- is valid only within the UK
- has to be read, considered and used as a whole document – it may be misleading and will be incomplete to be selective
- is copyright of the BBA
- is subject to English Law.

17.2 Publications, documents, specifications, legislation, regulations, standards and the like referenced in this Certificate are those that were current and/or deemed relevant by the BBA at the date of issue or reissue of this Certificate.

17.3 This Certificate will remain valid for an unlimited period provided that the product/system and its manufacture and/or fabrication, including all related and relevant parts and processes thereof:

- are maintained at or above the levels which have been assessed and found to be satisfactory by the BBA
- continue to be checked as and when deemed appropriate by the BBA under arrangements that it will determine
- are reviewed by the BBA as and when it considers appropriate.

17.4 The BBA has used due skill, care and diligence in preparing this Certificate, but no warranty is provided.

17.5 In issuing this Certificate the BBA is not responsible and is excluded from any liability to any company, firm, organisation or person, for any matters arising directly or indirectly from:

- the presence or absence of any patent, intellectual property or similar rights subsisting in the product/system or any other product/system
- the right of the Certificate holder to manufacture, supply, install, maintain or market the product/system
- actual installations of the product/system, including their nature, design, methods, performance, workmanship and maintenance
- any works and constructions in which the product/system is installed, including their nature, design, methods, performance, workmanship and maintenance
- any loss or damage, including personal injury, howsoever caused by the product/system, including its manufacture, supply, installation, use, maintenance and removal
- any claims by the manufacturer relating to CE marking.

17.6 Any information relating to the manufacture, supply, installation, use, maintenance and removal of this product/system which is contained or referred to in this Certificate is the minimum required to be met when the product/system is manufactured, supplied, installed, used, maintained and removed. It does not purport in any way to restate the requirements of the Health and Safety at Work etc. Act 1974, or of any other statutory, common law or other duty which may exist at the date of issue or reissue of this Certificate; nor is conformity with such information to be taken as satisfying the requirements of the 1974 Act or of any statutory, common law or other duty of care.